

INSTRUCTIONS and GAME RULES

CARROM[®]

Electrical Rating:
120 VOLTS - AC only 25 WATTS/60 HZ POLARIZED PLUG

MODEL NO. 275.C
AGES 8 TO ADUL

IMPORTANT SAFETY INSTRUCTIONS READ ALL INSTRUCTIONS

CAUTION: This is not a toy and is intended for use by or under the supervision of adults.

PARENTS PLEASE NOTE!

Motor cord, cord plug and motor grille should be checked regularly. Any damage or hazardous condition should be corrected immediately. Do not use this game until properly repaired.

After play, always be sure the cord is disconnected from the electrical outlet to eliminate any risk of fire.

IMPORTANT: A balanced motor assembly in this game will give you maximum service....If dropped or handled improperly, the motor assembly could be damaged and cause the game to malfunction.

WARNING: TO AVOID ELECTRIC SHOCK, DISCONNECT THE CORD PLUG FROM THE ELECTRICAL OUTLET BEFORE SERVICING THE GAME. NEVER USE A METALLIC PROBE TO OPEN PLUGGED AIR HOLES IN THE PLAY AREA SURFACE.

SAVE THESE INSTRUCTIONS

ASSISTANCE HOTLINE 1-800-223-6047

IF YOU ARE MISSING A PART, REQUIRE HELP, OR ARE HAVING A PROBLEM WITH THE PERFORMANCE OF THIS GAME, PLEASE CALL FOR ASSISTANCE BEFORE RETURNING THE GAME TO THE STORE.

ASSEMBLY INSTRUCTIONS

FASTENERS USED:

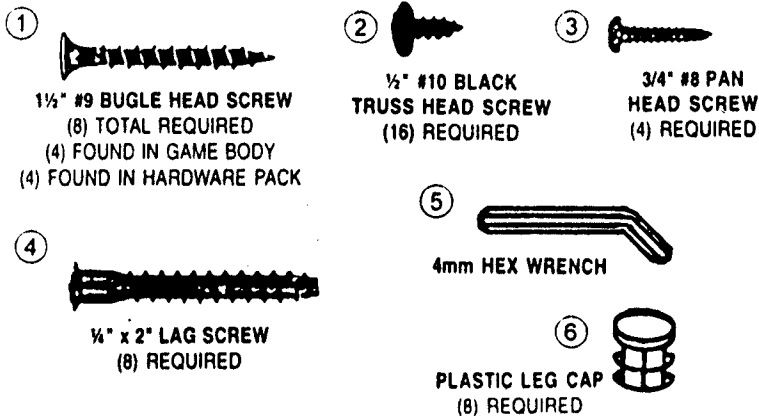

STEP 1. Insert two plastic plugs (#6) into each of (4) legs as shown in Figure (A).

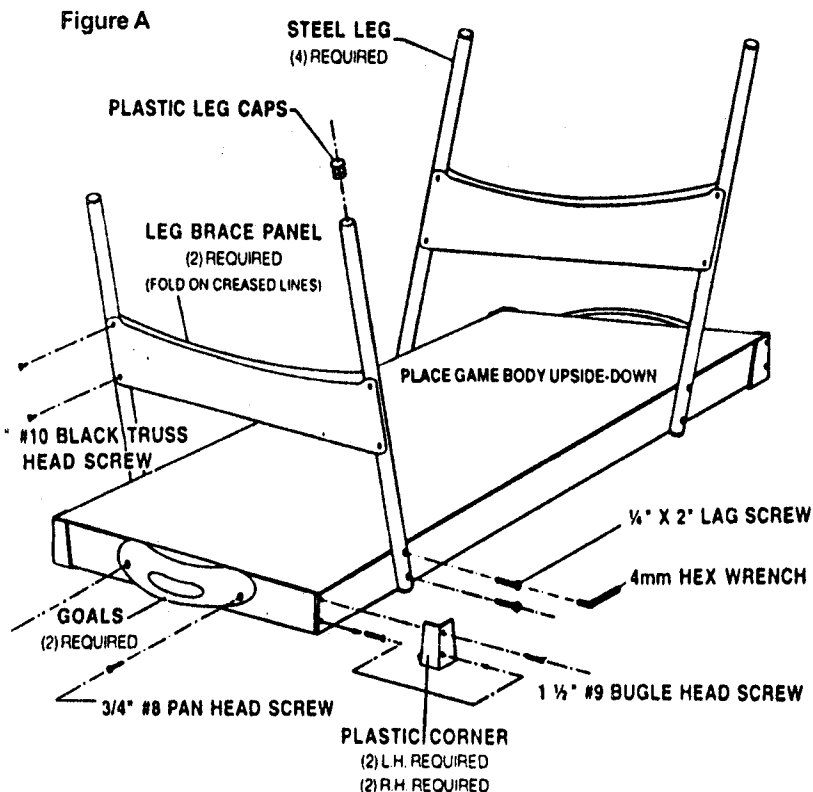

STEP 2. Place the game with the face side (playing surface) down on the floor or a table.

STEP 3. Fasten each of (4) legs to the game body sides as shown in figure (A), using (2) 1/4 x 2 long lag screws, (#4). Use the 4mm Hex Key (#5), included in hardware pack, to tighten these (8) screws.

STEP 4. Fold each of the (2) leg brace panels along the two center creases.

STEP 5. Install (1) folded leg brace panel between a pair of legs at each game end. Align the holes in the panel with the holes in the legs. Install (8) #10 x 1/2 truss head screws (#2) to fasten each leg panel in position. **DO NOT OVERTIGHTEN THESE SCREWS.**

STEP 6. Turn game assembly upright and place on a level floor.

STEP 7. Remove (1) screw from each corner of the game. See Figure (A). Note that there are (2) left hand and (2) right hand plastic corners. Place a plastic corner over a game body corner and carefully replace (1) 1 1/2 #9 bugle head screw that was earlier removed along with (1) 1 1/2 #9 bugle head screw from the hardware pack (#1). This will secure the plastic corner to the game body. **DO NOT OVERTIGHTEN THESE SCREWS,** repeat this step for the remaining (3) corners.

STEP 8. Install (1) goal on each end of the game body as shown in Figure (A) using (2) #8 x 3/4 pan head screws (#3).

STEP 9. Install (1) score keeper label in the top of each goal as shown in Figure (B).

STEP 10. Snap the score keeper pointer into position by forcing it over the raised lip on the goal (refer to Figure (B)).

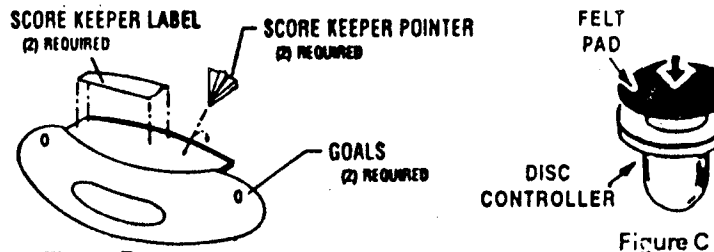

Figure B

Figure C

STEP 11. Peel away the backing from each felt pad. Carefully align and press into position, centering the pad on the controller as shown in Figure (C). **DO NOT USE** the controller without pads. Replace pads when worn to avoid scratching playing surface.

STEP 12. Plug the games' blower unit into a 110-120 volt AC polarized outlet only. This game is equipped with a polarized, alternating current line plug (a plug having one blade wider than the other). This is a safety feature. If you are unable to insert the plug fully into the outlet, try reversing the plug. If the plug should still fail to fit, your outlet is obsolete and should be replaced by a qualified electrician. Do not alter this plug. Do not defeat the safety purpose of the polarized plug.

You are now ready to play.

Please retain all instructions for future reference.

RULES FOR PLAY

Play should be started with a 1-2-3 "face-off" in the center of the game. The object is to get the puck in the opponent's goal and players should stand at each opposite end of the playing surface. Players may not cross beyond the center line of the game with puck controllers. The goal must be guarded from a position outside the "goal zone". When a goal is made, the puck is put in play by the player not having made the goal. The winning score is set at a nominal figure by agreement between both players before starting play.

TABLE MAINTENANCE

Occasionally, some air holes in the playing surface may become clogged. If this happens you may reopen holes as follows: 1. DISCONNECT THE CORD PLUG FROM THE ELECTRICAL OUTLET. 2. Carefully push a thin, non-metallic probe into each clogged hole. (A broom straw or wooden toothpick are good tools.) Be careful not to damage the mouth of the hole being reopened. **Warning: to avoid electric shock, never use a metallic probe to reopen air holes in play surface.**

DO NOT USE HOUSEHOLD WAXES ON SURFACE as the "air cushion" may be affected due to the clogging of holes. If a puck becomes rough, carefully sand by placing it on a piece of fine sandpaper (#280 or #320 grit) and slide the puck back and forth until the roughness disappears.