



## Assembly Instructions

Thank you for purchasing a Shelti product. All of us at Shelti want you to be completely satisfied with your Pro Foos game, so feel free to contact us for help with the assembly of your product, Shelti parts, or other information you may require.

### Tools Required:

- 1/2" Wrench
- 3/4" Wrench
- Hammer
- Phillips screwdriver
- Level

### STEP #1

- Remove the following parts from the Pro Foos II accessory box.

<u>Description</u>	<u>Part Number</u>	<u>Quantity</u>
Shelti Soccer Leg Assembly	CS-SSL-0	4
Goalie Rod Assembly	CS-GRA-0	2
5 - Man Rod Assembly	CS-5RA-0	2
3 - Man Rod Assembly	CS-3RA-0	2
2 - Man Rod Assembly	CS-2RA-0	2
C - Accessories Bag	CS-ASA-0	1
C - Assembly Instructions	210-0001-0	1
Shelti Rubber Bumper	203-0001-0	16
Shelti Soccer Man Red	201-0001-0	13
Shelti Soccer Man Black	201-0005-0	13
Spirol Pin	205-0006-0	26
5/16" Flat Washer	303-0002-0	8
5/16" Hex Nuts	302-0002-0	8
Score Posts	201-0006-0	4
Score Rods	205-0007-0	2
Red Score Beads	003-0002-0	5
Black Score Beads	003-0003-0	5
#8 x 2" Wood Screw	304-0005-0	4
Spirol Pin Punch	210-0012-0	1
Super Lube Tube	210-0002-0	1
Balls	201-0007-0	3
Rod Block	102-0070-0	1

## STEP #2 – Leg Assembly

- Carefully lay the table upside down on a cushioned surface (carpeting, blanket, etc.) to prevent damaging the cabinet laminate.
- Assemble the legs using the holes in the leg pads. Tighten nuts with a 1/2" wrench.

### For Installing *Optional* Commercial Duty 3½" x 5½" Legs

- Carefully lay the table upside down on a cushioned surface (carpeting, blanket, etc.) to prevent damaging the cabinet laminate.
- Viewing the table from either long side (the sides with rod holes), install a left leg (coded "L") on the left hand side of the table by inserting the leg's threaded studs into and through the mounting pad holes. Then secure with a flat washer/split-lock washer/ hex nut (see drawing). Install a right leg (coded "R") in the same manner on the other end of the same long side.
- Move to the other long side of the table and repeat the process.

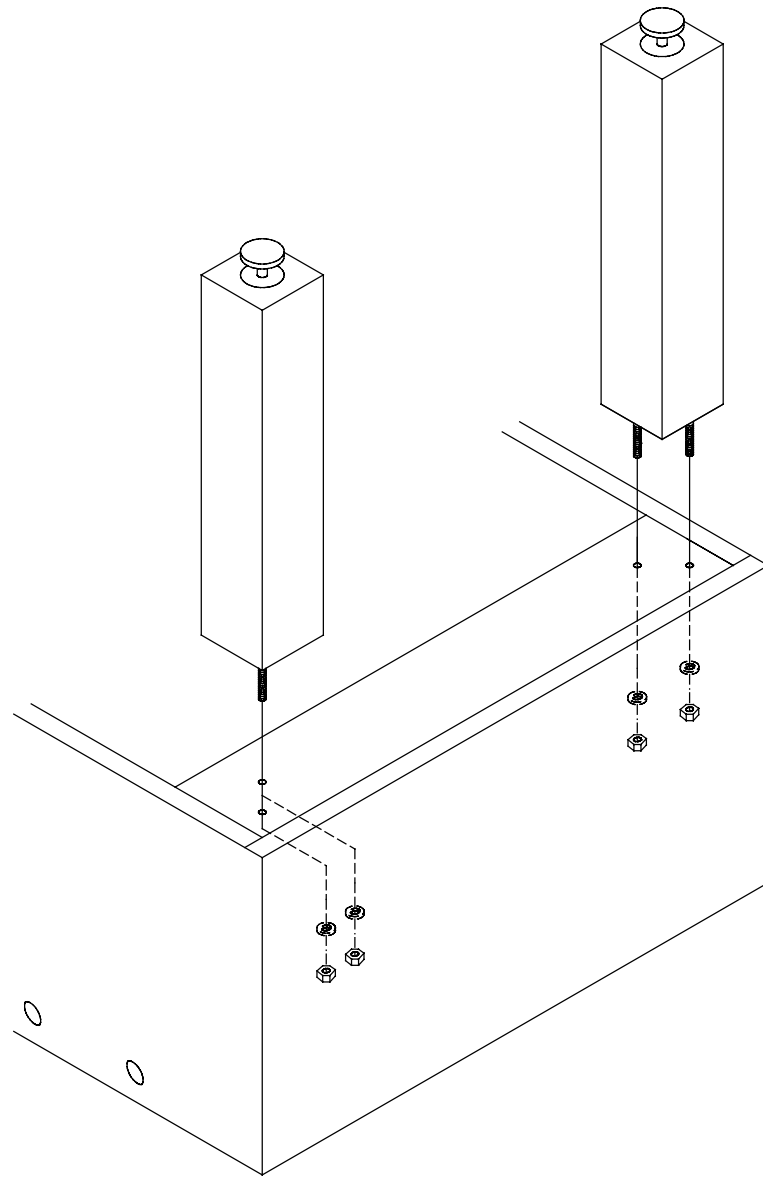

### STEP #3 – Rods, Bumper And Men Assembly

- Once the table legs are secure, (using two people) pick the table up and turn it over onto its legs.
- Locate the five man rods... These two rods will be located in the center of the game as illustrated below. Note... The men are designed with a slight press fit onto the rods in order to maximize playability.
  - Place the five man rod through the bushing in one wall... Slide on the first bumper making sure that the larger hole in the bumper is away from the wall and toward the man. This will allow the bumper to snap onto the shoulder of the outside man.
  - Slide on the five men and the second bumper and slide the rod through the bushing hole in the far wall... Note that the red and black men face in opposite directions as shown in the illustration. In some cases you may need to add a small amount of lubricant inside the shoulder hole of the man to ease the sliding of the man onto the rod.
  - Align each man over a hole in the rod and drive in a spirol pin. Note: place the rod block under the rod before hammering in the spirol pins.
  - Snap the bumpers onto the shoulder of the outside men. This can be done by pulling/pushing the men into the side walls until the bumpers are securely seated.
- Repeat these operations for the 3-man, 2-man, and goalie rods. Note: the 3-man and goalie rods both have three holes. The goalie rod is the shorter rod.

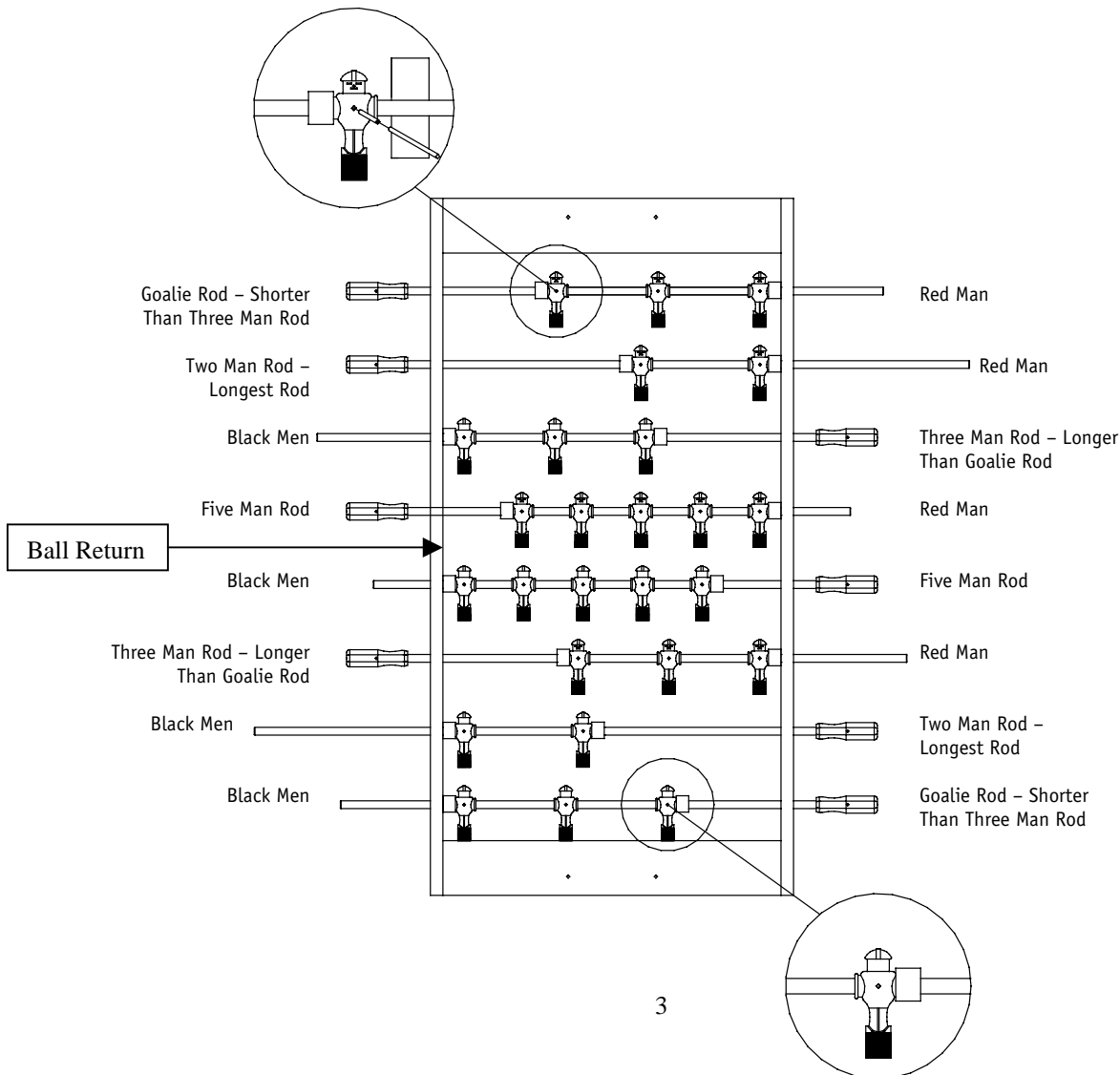

#### STEP #4 – Score Post & Rod Assembly

- Assemble the score posts - score rod - beads.
- Screw the score posts to the top of the game.
- The black scoring assembly contains 4 black beads and 1 red bead and should be placed at the end of the table where the black goalies are located. The odd colored bead signifies the final point and should be placed so that it is the last bead pulled toward you (the black team). The red team scoring assembly on the other side is just the opposite.

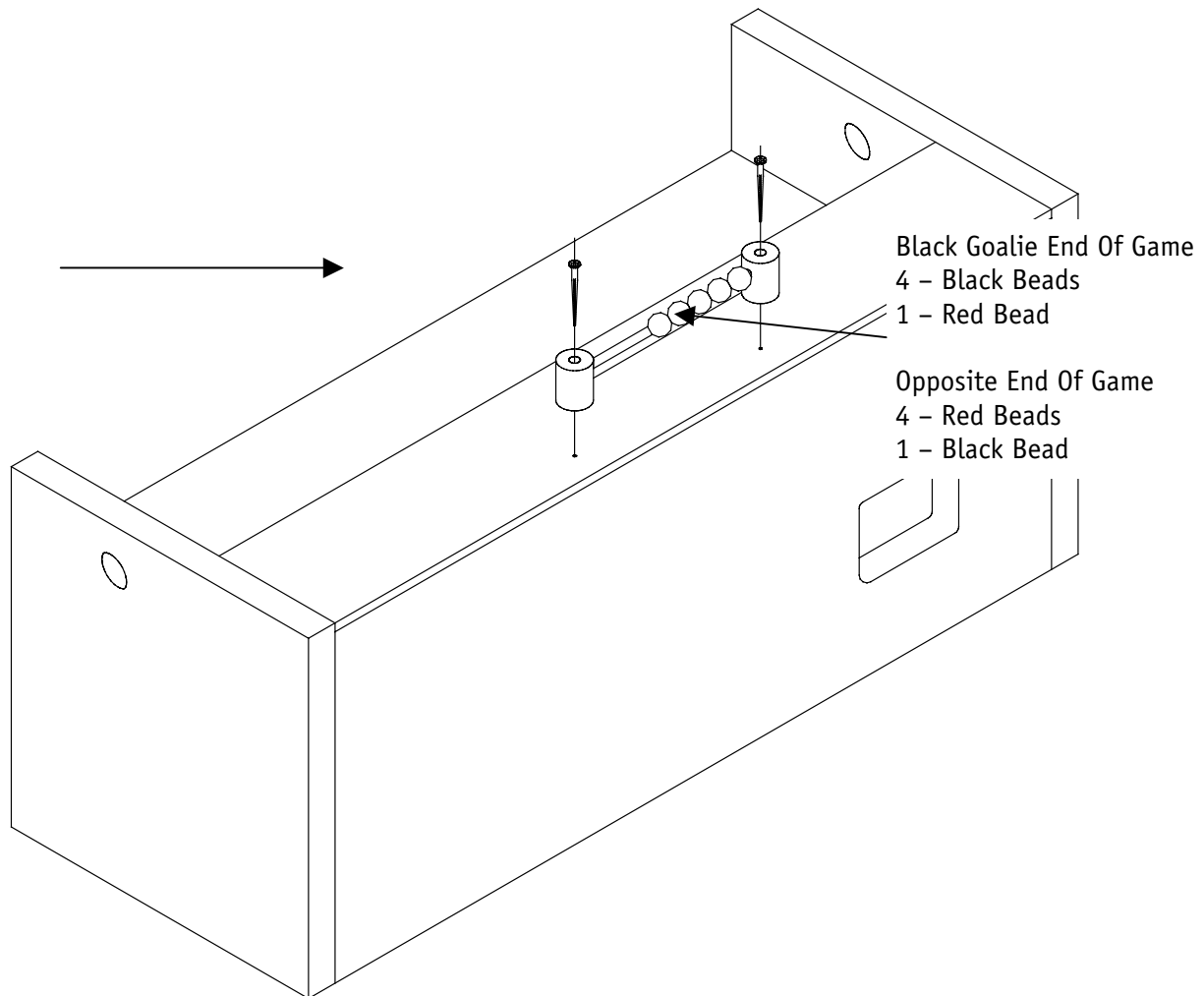

#### STEP #5 – Level The Game

- Turn the leg levelers in or out of the leg until the ball rolls true on the play surface.
- For more precise leveling, use a level. Place the level horizontally on the playing surface pointing toward the goal openings. Be sure all the levelers are screwed all the way in as a starting point. Turn the leg levelers up equally on one end until you are horizontally level. Then turn your level 90° so it is pointing toward the ball server holes. Now turn the levelers up on one side of the table until you are vertically level.

## STEP #6 – Lubricate The Rods / Bearings

- Push the rod away from you until the bumper hits the opposite wall. Apply two or three drops of lubricate on the face of the bearing and rod using the Super Lube Tube furnished with the game. Rotate the rod while pulling the rod toward you to evenly spread the lubricant on the rod. Perform the same operation on the opposite bearing face and rod. Repeat as needed.

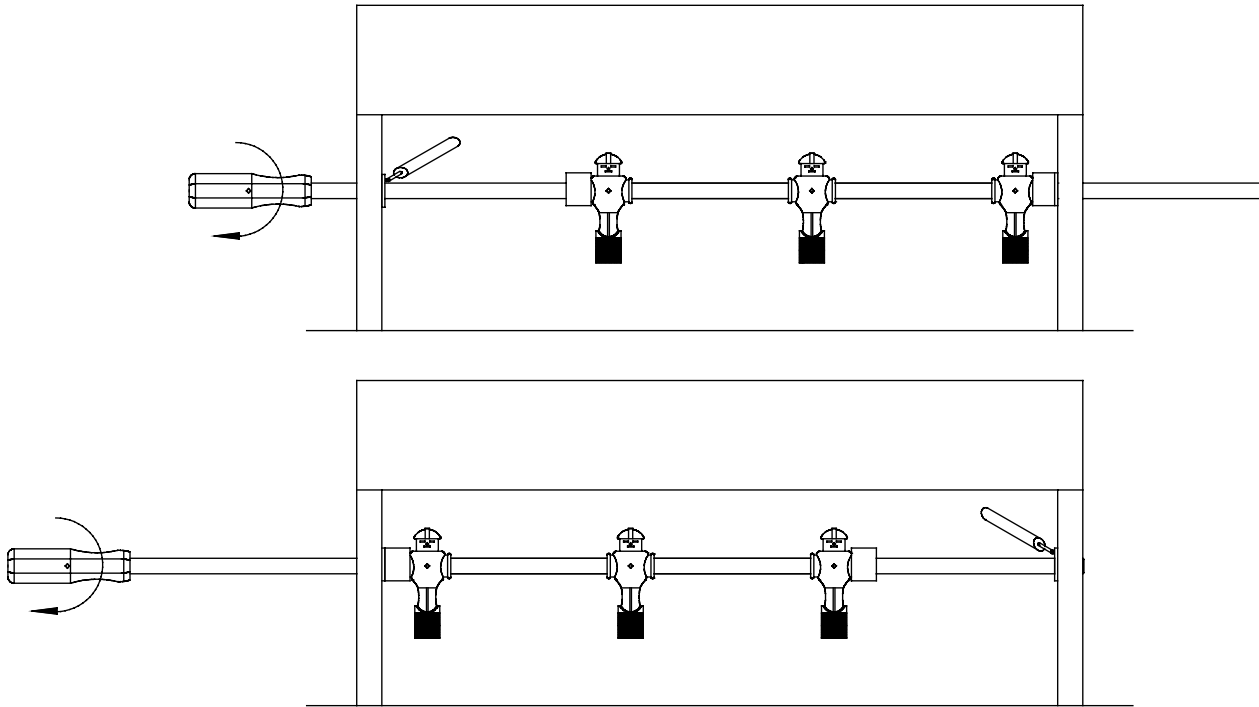

## STEP #7 – Rotating The Bushings

- Once a year the bushings should be rotated 180 degrees to assure an even wear of the bushing surface. To accomplish this rotation remove the rods from the game and push a 7/8" socket head over the bushing fingers (Drawing - A). Push the bushing out of the hole and rotate the bushing 180 degrees (Drawing - B). Snap the bushing back into place and return the rod and men to the game.

